



## 700MHz-1000MHz, 150W, 28V High Power RF LDMOS FETs

### Description

The ITBH09150B is a 150-watt, internally matched LDMOS FET, designed for CDMA/WCDMA and multicarrier GSM base station applications with frequencies from 700 to 1000 MHz. It Can be used in Class AB/B and Class C for all typical cellular base station modulation formats.

•Typical Performance (On Innogrations fixture with device soldered):

$V_{DD} = 28$  Volts,  $I_{DQ} = 1000$  mA, Pulse CW, Pulse Width=100 us, Duty cycle=10% .

Frequency	Gp (dB)	P <sub>-1dB</sub> (dBm)	$\eta_D@P_{-1}$ (%)	P <sub>-3dB</sub> (dBm)	$\eta_D@P_{-3}$ (%)
960 MHz	20.5	51.9	62.5	53	67.9

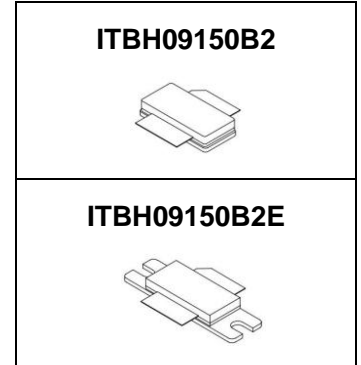

### Features

- High Efficiency and Linear Gain Operations
- Integrated ESD Protection
- Internally Matched for Ease of Use
- Excellent thermal stability, low HCl drift
- Large Positive and Negative Gate/Source Voltage Range for Improved Class C Operation
- Compliant to Restriction of Hazardous Substances (RoHS) Directive 2002/95/EC

**Table 1. Maximum Ratings**

Rating	Symbol	Value	Unit
Drain--Source Voltage	$V_{DSS}$	+75	Vdc
Gate--Source Voltage	$V_{GS}$	-10 to +10	Vdc
Operating Voltage	$V_{DD}$	+32	Vdc
Storage Temperature Range	$T_{stg}$	-65 to +150	°C
Case Operating Temperature	$T_c$	+150	°C
Operating Junction Temperature	$T_j$	+225	°C

**Table 2. Thermal Characteristics**

Characteristic	Symbol	Value	Unit
Thermal Resistance, Junction to Case $T_c = 85^\circ\text{C}$ , $T_j = 200^\circ\text{C}$ , DC test	$R_{\theta JC}$	0.38	°C/W

**Table 3. ESD Protection Characteristics**

Test Methodology	Class
Human Body Model (per JESD22--A114)	Class 2

**Table 4. Electrical Characteristics** ( $T_A = 25^\circ\text{C}$  unless otherwise noted)

Characteristic	Symbol	Min	Typ	Max	Unit
----------------	--------	-----	-----	-----	------

#### DC Characteristics

Drain-Source Breakdown Voltage ( $V_{GS} = 0\text{V}$ ; $I_D = 100\mu\text{A}$ )	$V_{DSS}$	75			V
Zero Gate Voltage Drain Leakage Current ( $V_{DS} = 28\text{V}$ , $V_{GS} = 0\text{V}$ )	$I_{DSS}$			1	$\mu\text{A}$



Gate--Source Leakage Current ( $V_{GS} = 6\text{ V}$ , $V_{DS} = 0\text{ V}$ )	$I_{GSS}$			1	$\mu\text{A}$
Gate Threshold Voltage ( $V_{DS} = 28\text{ V}$ , $I_D = 0.8\text{ mA}$ )	$V_{GS(th)}$		2.1		V
Gate Quiescent Voltage ( $V_{DD} = 28\text{ V}$ , $I_{DQ} = 1000\text{ mA}$ , Measured in Functional Test)	$V_{GS(Q)}$	2.6	3.1	3.6	V

**Functional Tests (In Innogrations Test Fixture, 50 ohm system) :**  $V_{DD} = 28\text{ Vdc}$ ,  $I_{DQ} = 1000\text{ mA}$ ,  $f = 960\text{ MHz}$ , Pulse CW Signal Measurements.  
(Pulse Width=100  $\mu\text{s}$ , Duty cycle=10%)

Power Gain	$G_p$		20.5		dB
Drain Efficiency@P3dB	$\eta_D$		67.9		%
1 dB Compression Point	$P_{-1dB}$		51.9		dBm
3dB Compression Point	$P_{-3dB}$		53		dBm
Input Return Loss	IRL		-7		dB

**Load Mismatch (In Innogrations Test Fixture, 50 ohm system):**  $V_{DD} = 28\text{ Vdc}$ ,  $I_{DQ} = 1000\text{ mA}$ ,  $f = 960\text{ MHz}$

VSWR 10:1 at 150W pulse CW Output Power	No Device Degradation
---	-----------------------

Reference Circuit of Test Fixture Assembly Diagram

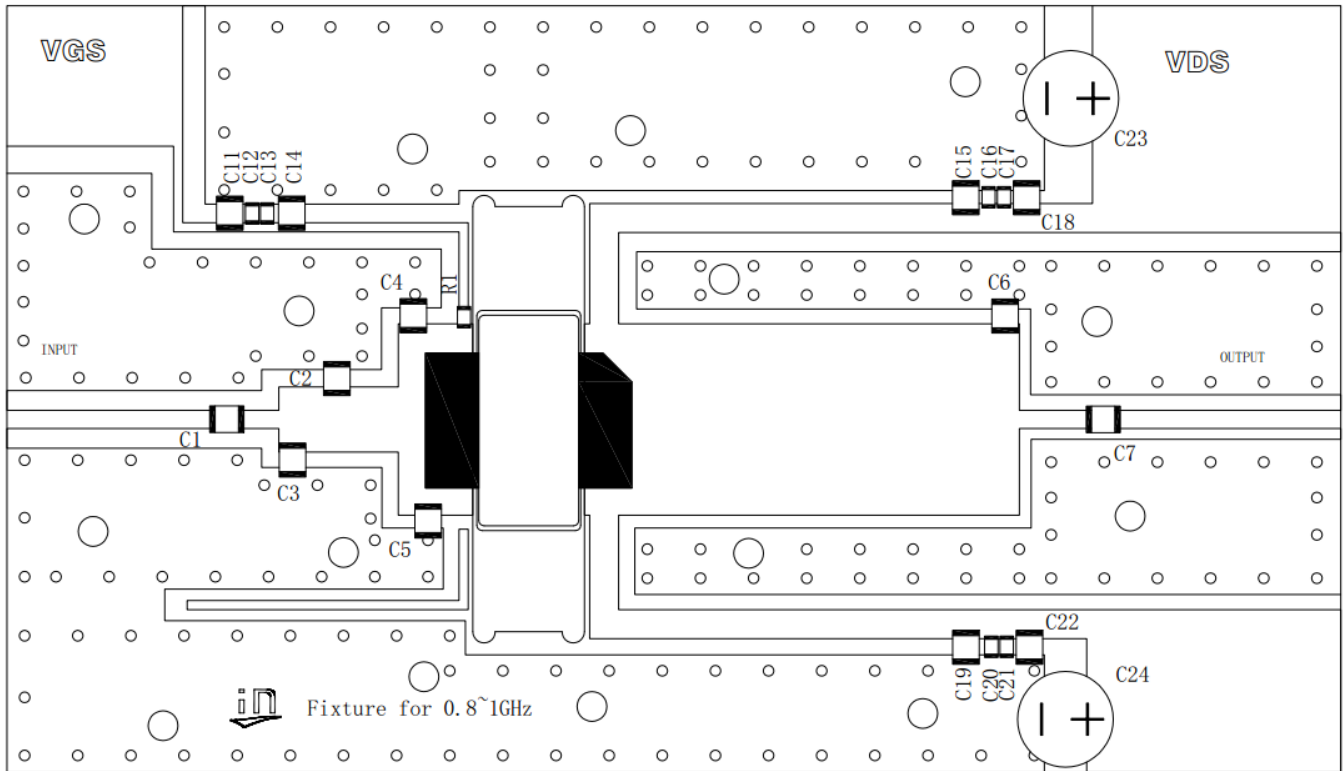

Figure 1. ITBH09150B Test Circuit Component Layout (920MHz~960MHz)

Table 5. ITBH09150B (920MHz~960MHz) Test Circuit Component Designations and Values

Component	Description	Suggested Manufacturer	P/N
C1,C7,C14,C15,C19	Ceramic Capacitor,47pF	ATC	800B470
C2	Ceramic Capacitor,6.2pF	ATC	800B 6R2
C3	Ceramic Capacitor,2.7pF	ATC	800B 2R7
C4,C5	Ceramic Capacitor,9.1pF	ATC	800B 9R1
C6	Ceramic Capacitor,1.0pF	ATC	800B 1R0
C13,C16,C20	Capacitor,1000pF	Murata	GRM21BR71H102
C12,C17,C21	Capacitor,0.1uF	Murata	GRM21BR71H104
C11,C18,C22	Capacitor,10uF	Murata	GRM32DF51H106
C23,C24	Electrolytic Capacitor ,470uF,63V	Vishay	MAL203858471E3
R1	Chip Resistor,10Ω	Digi-Key	P10ECT-ND
PCB	0.76mm [0.030"] thick, εr=3.48, Rogers RO4350, 1 oz. copper		

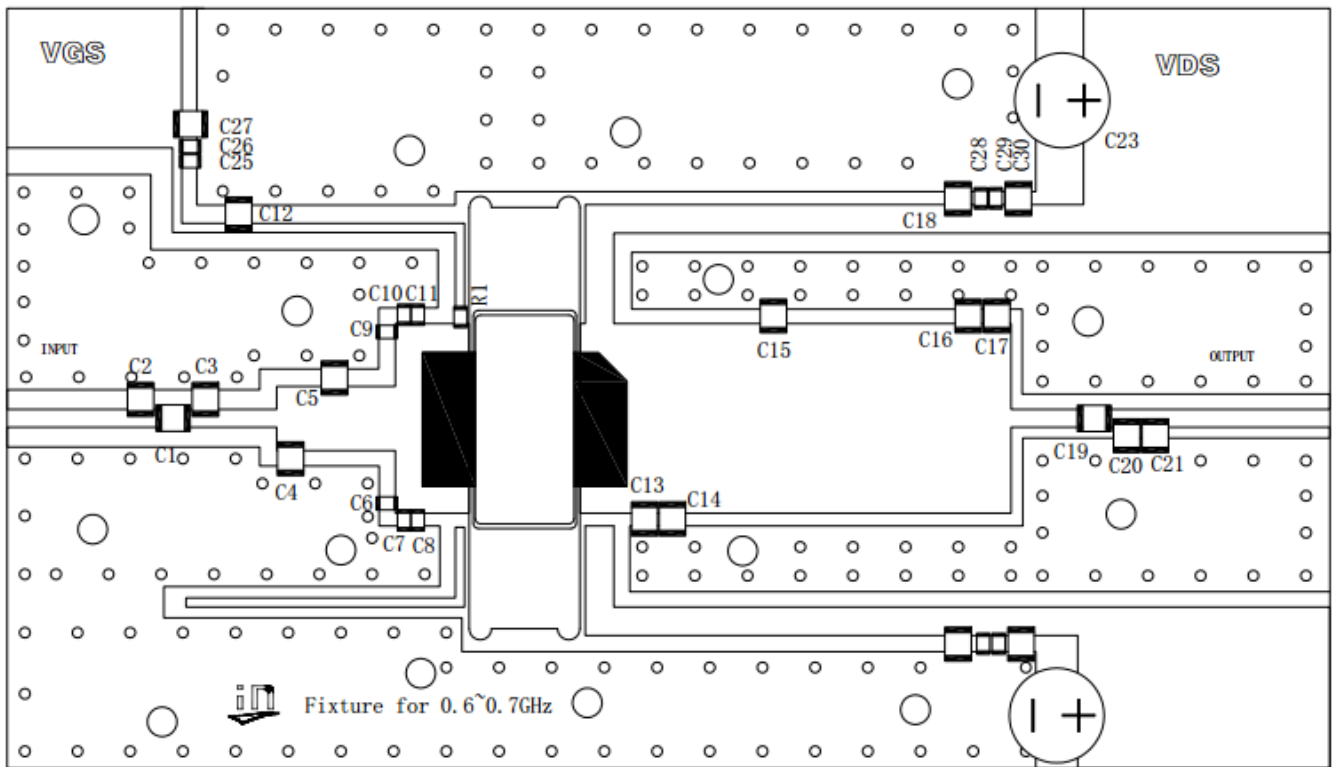

Figure 2. ITBH09150B Test Circuit Component Layout (610MHz~680MHz)

Table 6. ITBH09150B (610Mz~680MHz) Test Circuit Component Designations and Values

Component	Description	Suggested Manufacturer	P/N
C1,C12,C18,C19	Ceramic Capacitor,47pF	ATC	
C2	Ceramic Capacitor,1.2pF	ATC	
C3,C14	Ceramic Capacitor,4.7pF	ATC	
C4,C5,C6,C7,C8,C9,C10,C11,C13	Ceramic Capacitor,10pF	ATC	
C15,C16,C17	Ceramic Capacitor,5.6pF	ATC	
C20,C21	Ceramic Capacitor,2.7pF	ATC	
C25,C28	Capacitor,1000pF	Murata	
C26,C29	Capacitor,0.1uF	Murata	
C27,C30	Capacitor,10uF	Murata	
C23	Electrolytic Capacitor ,470uF,63V	Vishay	
R1	Chip Resistor,10Ω	Digi-Key	
PCB	0.76mm [0.030"] thick, εr=3.48, Rogers RO4350, 1 oz. copper		

### TYPICAL CHARACTERISTICS

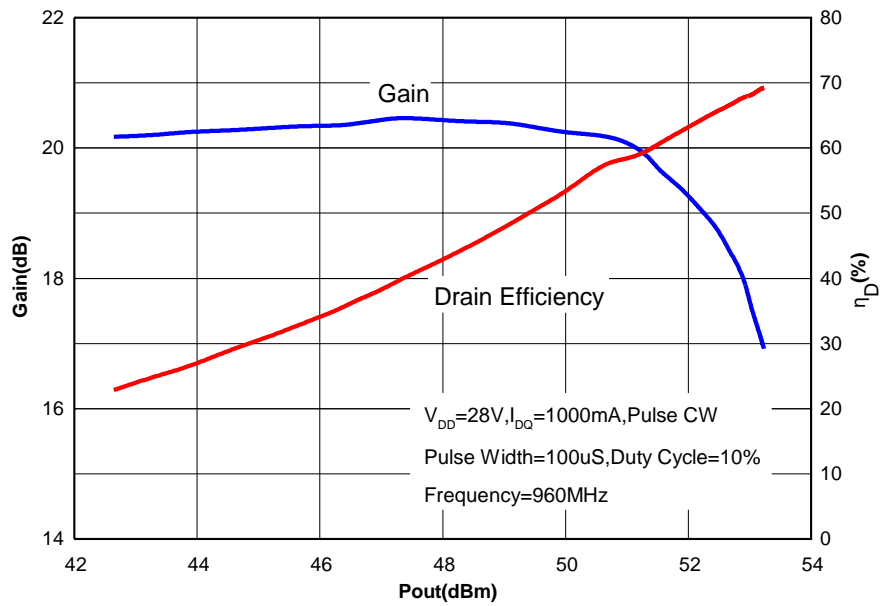

Figure 2. Power gain and drain efficiency as function of average load power (920MHz~960MHz)

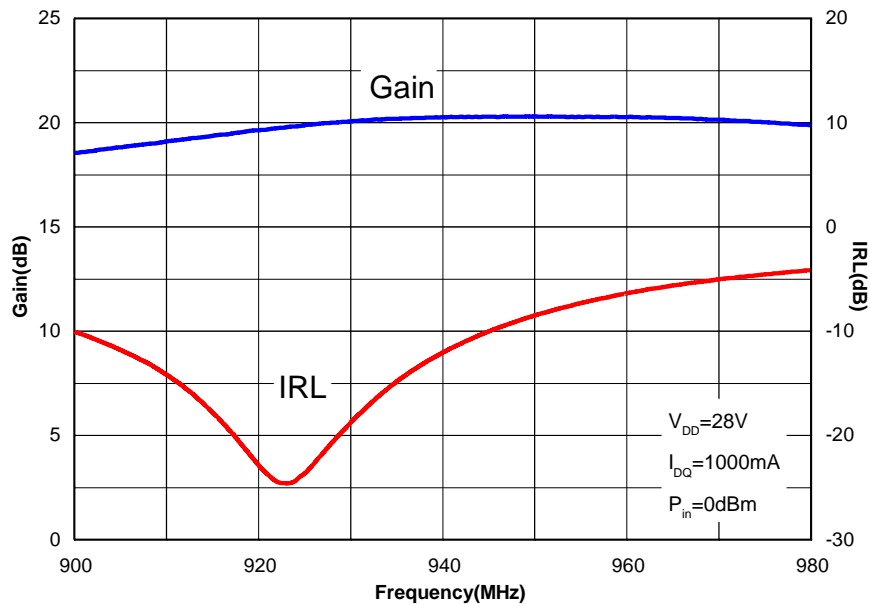
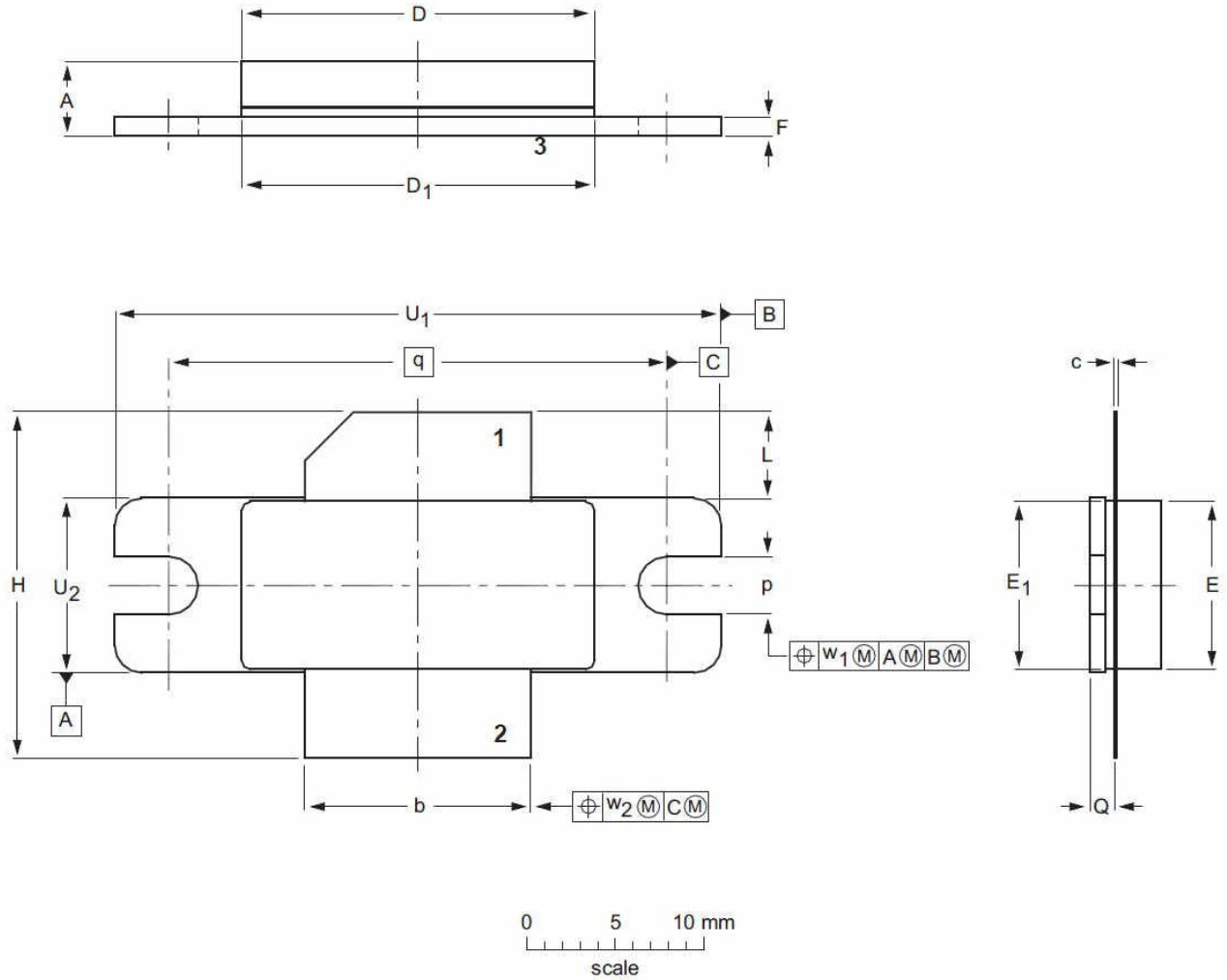

Figure 3. Broadband Frequency Response (920MHz~960MHz)



### Package Outline

Flanged ceramic package; 2 mounting holes; 2 leads (1—DRAIN、2—GATE、3—SOURCE)



UNIT	A	b	c	D	D <sub>1</sub>	E	E <sub>1</sub>	F	H	L	p	Q	q	U <sub>1</sub>	U <sub>2</sub>	W <sub>1</sub>	W <sub>2</sub>
mm	4.72	12.83	0.15	20.02	19.96	9.50	9.53	1.14	19.94	5.33	3.38	1.70	27.94	34.16	9.91	0.25	0.51
	3.43	12.57	0.08	19.61	19.66	9.30	9.25	0.89	18.92	4.32	3.12	1.45	1.100	33.91	9.65	0.01	0.02
inches	0.186	0.505	0.006	0.788	0.786	0.374	0.375	0.045	0.785	0.210	0.133	0.067	1.100	1.345	0.390	0.01	0.02
	0.135	0.495	0.003	0.772	0.774	0.366	0.364	0.035	0.745	0.170	0.123	0.057	1.100	1.335	0.380	0.01	0.02

OUTLINE VERSION	REFERENCE			EUROPEAN PROJECTION	ISSUE DATE
	IEC	JEDEC	JEITA		
PKG-B2E					03/12/2013



Earless flanged ceramic package; 2 leads (1—DRAIN、2—GATE、3—SOURCE)

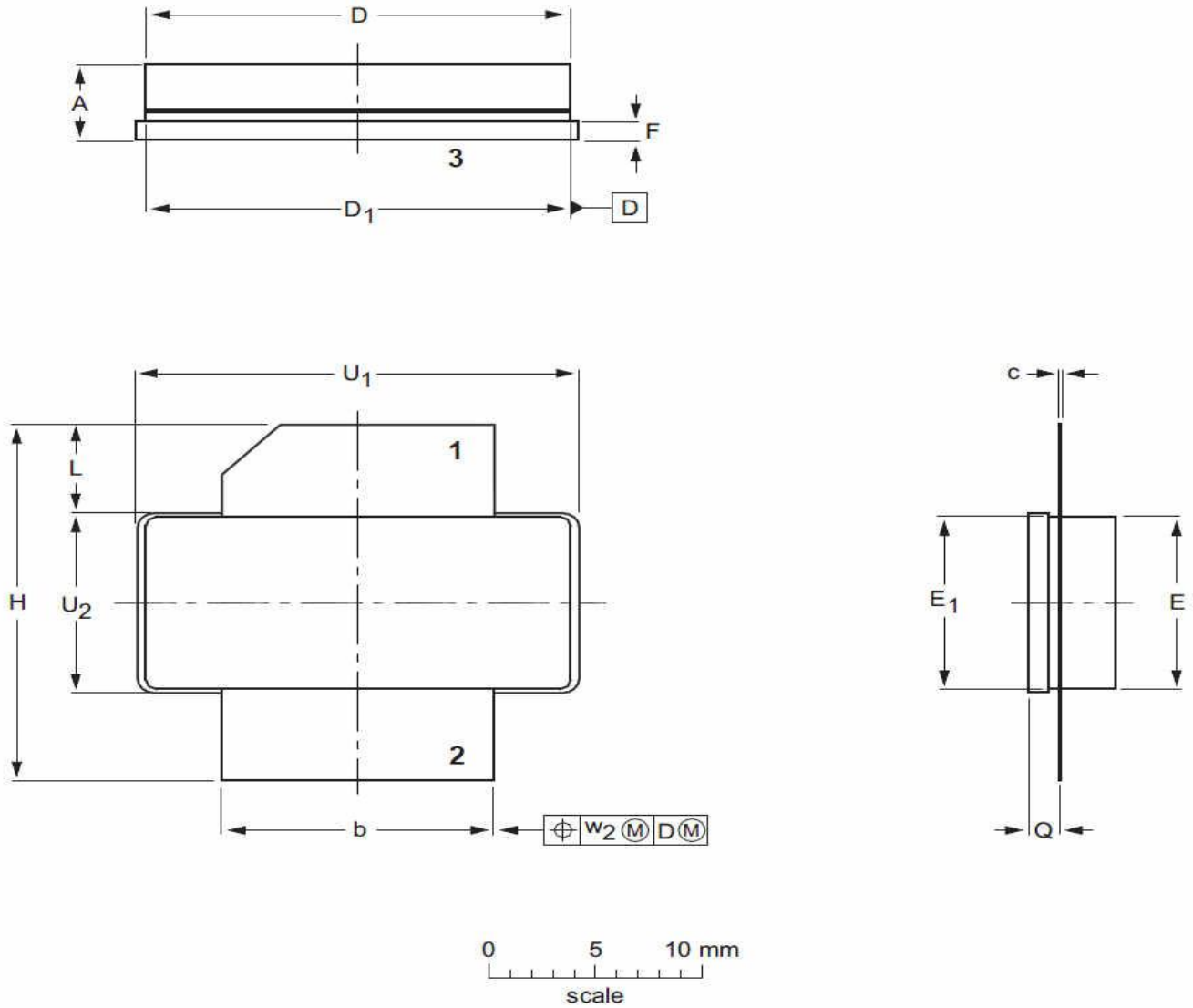

UNIT	A	b	c	D	D <sub>1</sub>	E	E <sub>1</sub>	F	H	L	Q	U <sub>1</sub>	U <sub>2</sub>	W <sub>2</sub>
mm	4.72	12.83	0.15	20.02	19.96	9.50	9.53	1.14	19.94	5.33	1.70	20.70	9.91	0.25
	3.43	12.57	0.08	19.61	19.66	9.30	9.25	0.89	18.92	4.32	1.45	20.45	9.65	
inches	0.186	0.505	0.006	0.788	0.786	0.374	0.375	0.045	0.785	0.210	0.067	0.815	0.390	0.010
	0.135	0.495	0.003	0.772	0.774	0.366	0.364	0.035	0.745	0.170	0.057	0.805	0.380	

OUTLINE VERSION	REFERENCE			EUROPEAN PROJECTION	ISSUE DATE
	IEC	JEDEC	JEITA		
PKG-B2					03/12/2013



## Revision history

Table 7. Document revision history

Date	Revision	Datasheet Status
2014/06/17	Rev 1.0	Preliminary Datasheet
2016/03/07	Rev 2.0	Product Datasheet

## Disclaimers

Specifications are subject to change without notice. Innogrations believes the information contained within this data sheet to be accurate and reliable. However, no responsibility is assumed by Innogrations for any infringement of patents or other rights of third parties which may result from its use. No license is granted by implication or otherwise under any patent or patent rights of Innogrations. Innogrations makes no warranty, representation or guarantee regarding the suitability of its products for any particular purpose. "Typical" parameters are the average values expected by Innogrations in large quantities and are provided for information purposes only. These values can and do vary in different applications and actual performance can vary over time. All operating parameters should be validated by customer's technical experts for each application. Innogrations products are not designed, intended or authorized for use as components in applications intended for surgical implant into the body or to support or sustain life, in applications in which the failure of the Innogrations product could result in personal injury or death or in applications for planning, construction, maintenance or direct operation of a nuclear facility. For any concerns or questions related to terms or conditions, pls check with Innogrations and authorized distributors

Copyright © by Innogrations (Suzhou) Co.,Ltd.